



a JSJ business

## DAKE SINGLE LEVERAGE ARBOR PRESS

# Model Y

INSTRUCTIONAL MANUAL



### WARNING!

Read and understand all instructions and responsibilities before operating. Failure to follow safety instructions and labels could result in serious injury.

Dake Corporation  
724 Robbins Road  
Grand Haven, MI 49417

Phone: 800.937.3253  
Fax: 800.846.3253

[www.dakecorp.com](http://www.dakecorp.com)  
[customerservice@dakecorp.com](mailto:customerservice@dakecorp.com)



## TABLE OF CONTENTS

|                                     |   |
|-------------------------------------|---|
| DAKE STANDARD LIMITED WARRANTY..... | 2 |
| RETURN & REFUND POLICY .....        | 4 |
| SPECIFICATIONS .....                | 5 |
| SAFETY .....                        | 5 |
| MAINTENANCE .....                   | 6 |
| LUBRICATION .....                   | 6 |
| EXPLODED VIEW & PARTS LIST .....    | 6 |
| EXPLODED PARTS VIEW.....            | 6 |
| PARTS LIST .....                    | 7 |
| ORDERING INFORMATION .....          | 7 |



## DAKE STANDARD LIMITED WARRANTY

### *Finished Machines*

Dake warrants to the original purchaser the finished machine manufactured or distributed by it to be free from defects in material and workmanship under normal use and service within 1 year (12 months) from the delivery date to the end user.

### *Parts & Couplings*

Dake warrants to the original purchaser the component part or coupling manufactured or distributed by it to be free from defects in material and workmanship under normal use and service within 30 days from the delivery date to the end user.

The standard limited warranty includes the replacement of the defective component part or coupling, at no cost to the end user.

### **Warranty Process**

Subject to the conditions hereinafter set forth, the manufacturer will repair or replace any portion of the product that proves defective in materials or workmanship. The manufacturer retains the sole right and option, after inspection, to determine whether to repair or replace defective equipment, parts or components. The manufacturer will assume ownership of any defective parts replaced under this warranty.

All requested warranty claims must be communicated to the distributor or representative responsible for the sale. Once communication has been initiated, Dake Customer Service must be contacted for approval:

Phone: (800) 937-3253

Email: [customerservice@dakecorp.com](mailto:customerservice@dakecorp.com)

When contacting Dake, please have the following information readily available:

- Model #
- Serial #
- Sales Order #

Purchasers who notify Dake within the warranty period will be issued a Case number and/or a Return Material Authorization (RMA) number. If the item is to be returned per Dake's request, the RMA number must be clearly written on the exterior packaging. Any item shipped to Dake without an RMA will not be processed.



**Warranty Exceptions:**

The following conditions are not applicable to the standard limited warranty:

- (a) Part installation or machine service was not completed by a certified professional, and is not in accordance with applicable local codes, ordinances and good trade practices.
- (b) Defects or malfunctions resulting from improper installation or failure to operate or maintain the unit in accordance with the printed instructions provided.
- (c) Defects or malfunctions resulting from abuse, accident, neglect or damage outside of prepaid freight terms.
- (d) Normal maintenance service or preventative maintenance, and the parts used in connection with such service.
- (e) Units and parts which have been altered or repaired, other than by the manufacturer or as specifically authorized by the manufacturer.
- (f) Alterations made to the machine that were not previously approved by the manufacturer, or that are used for purposes other than the original design of the machine.



## RETURN & REFUND POLICY

Thank you for purchasing from Dake! If you are not entirely satisfied with your purchase, we are here to help.

### Returns

All Dake manufactured / distributed machines, parts and couplings include a 30-day return option. These policies are valid from the date of final shipment to the end user.

To be eligible for a return, the item must be unused and in the same condition as received.

All requested warranty claims must be communicated to the distributor or representative responsible for the sale. Once communication has been initiated, Dake Customer Service must be contacted for approval:

Phone: (800) 937-3253

Email: [customerservice@dakecorp.com](mailto:customerservice@dakecorp.com)

Once the return request has been approved by Customer Service, a representative will supply a Return Material Authorization (RMA) number. The returned item must have the provided RMA number clearly marked on the outside packaging. Any item received without an RMA number clearly visible on the packaging will not be processed.

An RMA number can only be provided by the Dake Customer Service team and must be obtained prior to the return shipment.

### Refunds

Once the item has been received and inspected for damages, a representative will notify the requestor referencing the provided RMA number.

If the return is approved, a refund will be issued to the original method of payment, less a 20% restocking fee. The restocking fee may be waived if an order is placed at the time of return with like-value merchandise.

Transportation costs are the responsibility of the end user and will not be credited upon return approval.

Any item that is returned after the initial 30 days or has excessive/obvious use will not be considered for a full refund.

## SPECIFICATIONS

|                   |            |
|-------------------|------------|
| Model             | Y          |
| Number            | 901002     |
| Capacity          | 1-1/2 tons |
| Leverage ration   | 32:1       |
| Ram size          | 1"x1"x12"  |
| Max diameter work | 9"         |

|                  |         |
|------------------|---------|
| Throat           | 4-1/2"  |
| Max ram to table | 7-3/4"  |
| Base length      | 15"     |
| Base width       | 6"      |
| Height           | 14-1/2" |
| Weight           | 60 lbs  |

## SAFETY



**WARNING:** This product contains Nickel, a chemical known to the State of California to cause cancer. For more information go to [www.P65Warnings.ca.gov](http://www.P65Warnings.ca.gov)



**This is the safety alert symbol.** When you see this symbol on your press be alert to the potential for personal injury.

Employer is responsible to perform a hazard/PPE assessment before work activity.



Label Part No. 300168



Label Part No.  
79979

Follow recommended precautions and safe operating practices.

|  |   |  |
|--|---|--|
| <p><b>Carefully read all safety messages in these instructions and on your press safety signs.</b> Keep safety labels in good condition. Replace missing or damaged safety labels.</p> | <p><b>This machine is intended to be operated by one person.</b> This person should be conscious of the press ram movement not only for themselves but also for persons in the immediate area of the machine.</p> | <p><b>Under no circumstances increase the leverage ratio of the press by using a longer handle or by placing a pipe over the handle.</b> Never hammer on top of the ram.</p> |
|--|---|--|

## MAINTENANCE

### LUBRICATION

- Keep all working parts of the press well-oiled for easier operation.
- Keep a light film of oil over the entire surface of the ram to prevent rust.

## EXPLODED VIEW & PARTS LIST

### EXPLODED PARTS VIEW

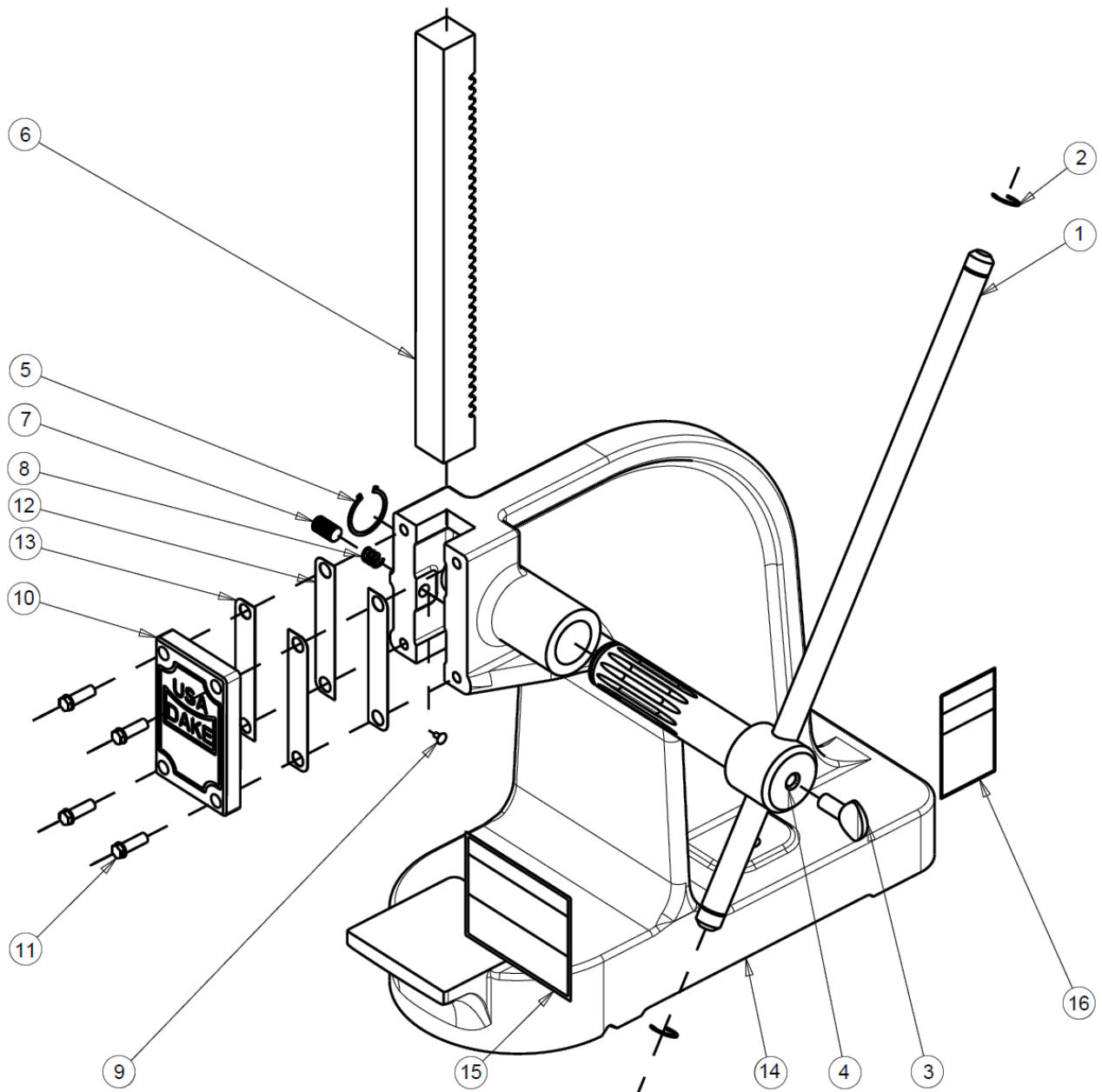



## PARTS LIST

| <u>Item</u> | <u>Part Name</u>                                     | <u>Part Number</u> | <u>Qty</u> |
|-------------|--|--------------------|------------|
| 1           | Handle   | 128                | 1          |
| 2           | Retaining Ring (National lock washer number XRC-327) | 43965              | 2          |
| 3           | Thumb Screw (3/8"-16 x 3/4")                         | 43622              | 1          |
| 4           | Spindle  | 129                | 1          |
| 5           | Retaining Ring                                       | 67424              | 1          |
| 6           | Ram  | 127                | 1          |
| 7           | Headless Set Screw (3/8"-16 x 5/8")                  | 43589              | 1          |
| 8           | Brake Spring   | 108                | 1          |
| 9           | Tinners Rivet  | 43577              | 1          |
| 10          | Ram Cap  | 122                | 1          |
| 11          | 5/16"-18 x 1" Hex Cap Screw                          | 43315              | 4          |
| 12          | Ram Cap Shim (.008")                                 | 125                | 2          |
| 13          | Ram Cap Shim (.015")                                 | 126                | 2          |
| 14          | Frame  | 101                | 1          |
| 15          | Warning Label – Ganged                               | 300168             | 1          |
| 16          | Warning Label – Tipping                              | 79979              | 1          |

*Please contact factory for current prices.*

## ORDERING INFORMATION

Parts are available for direct purchase from Dake or through a distributor. When placing a parts order, you will need to provide the part number, name of part, and model number. All parts shipped F.O.B. Factory in Grand Haven, MI.