

Utility Arbor 3 Ton

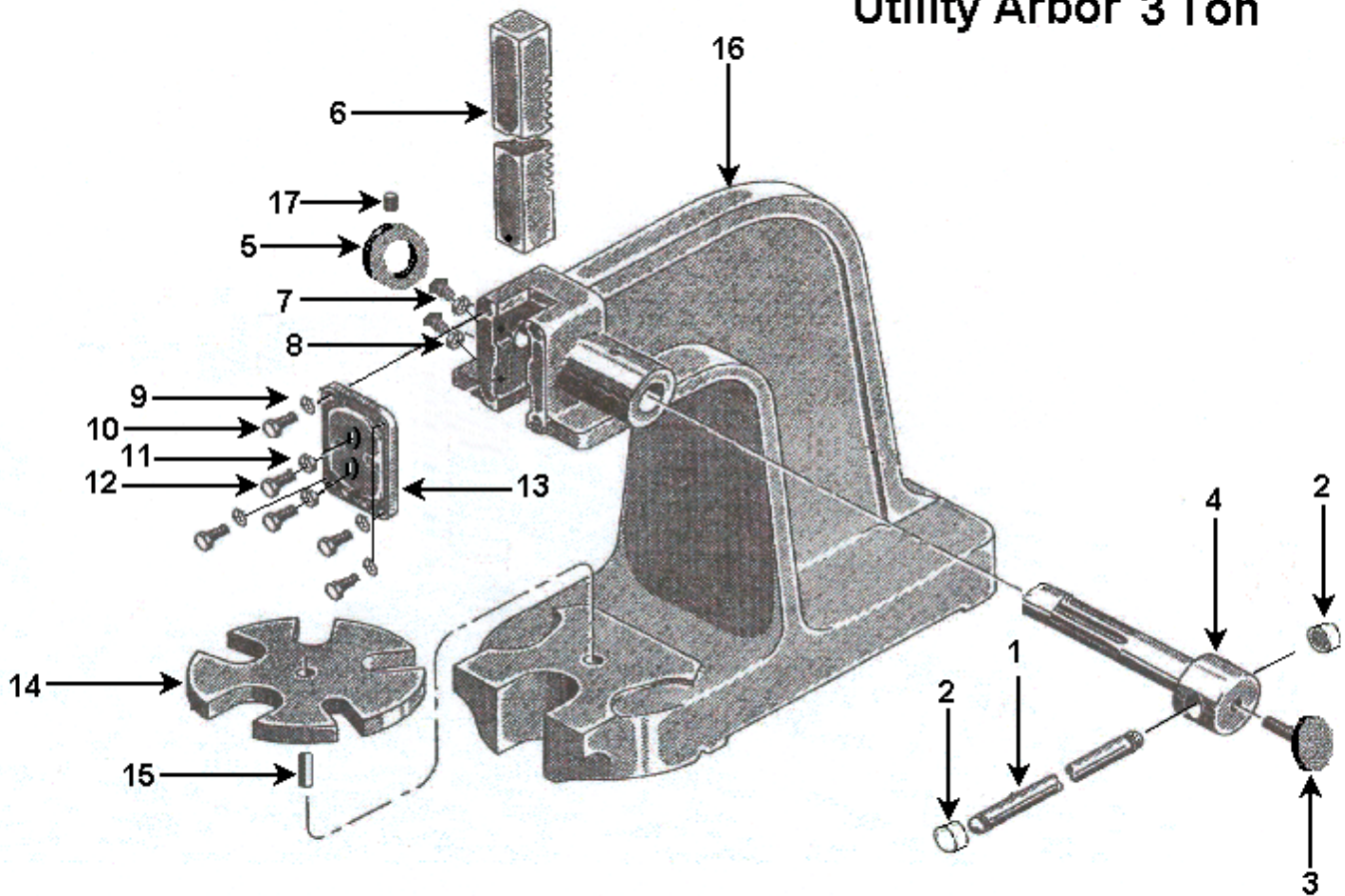

SAFETY

This is the safety alert symbol. When you see this symbol on your press, be alert to the potential for personal injury.

Follow recommended precautions and safe operating practices.

Carefully read all safety messages in these instructions and on your press safety signs. Keep safety labels in good condition. Replace missing or damaged safety labels.	This machine is intended to be operated by one person. This person should be conscious of the press ram movement not only for themselves but also for persons in the immediate area of the machine.	Under no circumstances increase the leverage ratio of the press by using a longer handle or by placing a pipe over the handle. Never hammer on top of the ram.
--	---	--



Utility Arbor 3 Ton

Single leverage arbor press

Instructions and parts list

Utility Line Arbor Press

<u>Item</u>	<u>Part Name</u>	<u>Quantity</u>	<u>Part Number</u>
1	Handle	1	301234
2	Handle cap	2	301235
3	Handle lock knob	1	301236
4	Spindle	1	301237
5	Spindle retaining collar	1	301238
6	Ram	1	301239
7	Ram brake adjusting bolt	2	301240
8	Ram brake adjusting bolt nut	2	301241
9	Washer	4	301242
10	Ram cap bolt	4	301243
11	Ram shim bolt nut	2	301244
12	Ram shim bolt	2	301245
13	Ram cap	1	301246
14&15	Table Plate assembly & Roll pin	1	301247
16	Frame	1	301248
17	Spindle collar set screw	1	301249

Please contact factory for current prices.

Ordering information: Please order all repair parts by part number and name, also mention model number of press. All parts are shipped F.O.B. Factory in Grand Haven, MI.

Lubrication: Keep all working parts of the press well oiled for easier operation. Also keep a light film of oil over the entire surface of the ram to prevent rust.

DAKE
 Division of JSJ Corp.
 724 Robbins Road
 Grand Haven, MI 49417

Phone: 616-842-7110 800-937-3253
 Fax: 616-842-0859 800-846-3253
 E-Mail: customerservice@dakecorp.com
 technicalservice@dakecorp.com
 Website: www.dakecorp.com