



INSTRUCTIONS AND PARTS LIST FOR MODEL 70H & 75H HAND-OPERATED HYDRAULIC PRESS

SETTING UP THE PRESS FOR OPERATION

For shipping convenience, the gauge, pump handle, hoist crank, screw nose and base angles were removed from the press. Assemble these parts to the press in the following order:

1. Bolt the base angles to the uprights using the four bolts and nuts furnished. Shoulder the base angles against the stops on the uprights.
2. Install the pressure gauge using a hydraulic sealant to ensure a sealed fit.
3. Insert pump handle into handle socket and fasten in place by means of the setscrew on top of the handle socket.
4. **CAUTION! Place the hoist crank on the lift drum shaft. The table is raised to the desired height by turning the crank after removing the table pins. Check to make sure the hoist cable is tracking correctly. Run the table channels from top to bottom. The cable should be on each of the two upper pulleys and should track back and forth on the cable drum. Always place table pins under the table channels when servicing or tracking the cable. If a tracking problem exists, contact the Dake factory for instructions. Be sure all table pins are fully inserted in place before applying pressure. Always remove or release pressure on the cable before pressure is applied.**
5. Fasten nosepiece to the end of the screw using the thumbscrew included.

OPERATIONS AND CONTROLS

The operator should acquaint himself with the use of the following controls:

1. The pump handle is the pressure supply source and is manually operated with an up and down motion.
2. Item number 45 (Part no. 10631) is the release valve handwheel. Always keep it firmly closed when operating the press and it should only be opened when releasing the pressure to allow the ram to return.
3. By turning Item 25 (Part No. 716520), the ram screw can be adjusted into or out of the piston assembly. Always keep the portion of the screw extending out of the piston as short as possible. It is advisable to raise the table one or two sets of holes rather than running the screw out to its limit of travel. **NEVER EXCEED THE RECOMMENDED STROKE OF 4 1/2 INCHES FOR THIS PRESS. EXCEEDING THE STROKE WILL CAUSE DAMAGE TO THE INNER PACKINGS.**
4. The two combination table plates-v blocks provided are used for supporting the work while it is being straightened.

FILLING THE PRESS WITH OIL

It is extremely important that new, clean, light hydraulic oil be used in this press, Mobil DTE 24 or an equivalent. It is strongly recommended that the oil be filtered to remove any possible dirt. The piston should be in its maximum upper position when filling the reservoir. Fill the reservoir with 4 quarts of oil. UNDER NO CIRCUMSTANCES USE OLD DIRTY OIL. Next remove the screw plug from the stand pipe on top of the workhead, close the release valve handwheel and pump oil into the workhead until oil is visible in the stand pipe. This will remove all air from the chamber above the piston. If oil leaks by the piston, the reservoir should be drained and refilled (4 quarts of oil) with the piston in the top position.

ORDERING INFORMATION

Please order all parts by number and name. Also mention model number and serial number as shown on the plate attached to the frame of the press. Prices for parts do not include shipping charges.

LUBRICATION

Keep all working parts of the press well oiled for easier operation. Also keep a light film of oil over the entire surface of the ram to prevent rust.

WARNING LABELS



To the left is the safety Alert symbol. When you see these safety alert symbols on your press, be alert to the potential for personal injury.

Follow recommended precautions and safe operating practices.

Carefully read all safety messages in these instructions and on your press safety signs. Keep safety labels in good condition. Replace missing or damaged safety labels. **This machine is intended to be operated by one person.** This person should be conscious of the press ram movement not only for himself but also for persons in the immediate area of the machine.



Label 300168



Label 84487



Label 84399



Label 6767

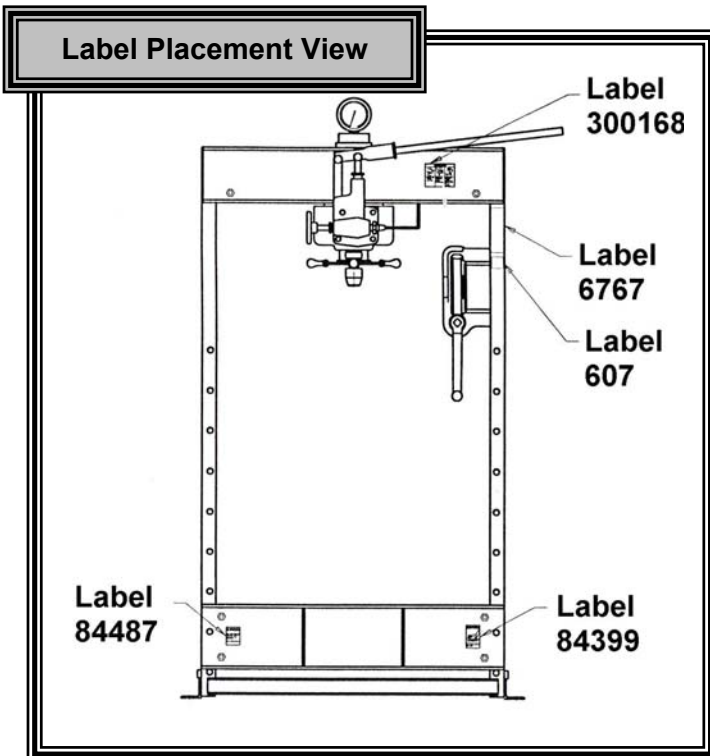

Label 607

TROUBLE SHOOTING – DAKE HAND HYDRAULIC PRESSES

PUMP PACKING LEAKAGE

If oil leaks past the pump packing, tighten the pump packing nut (551) until pump handle works hard, then slack off just enough to cause the handle to stay in position by itself. After long periods of operation, it may be necessary to install new pump packings.

IF PRESS DOES NOT HOLD PRESSURE

This condition is nearly always caused by dirt under pressure ball valve part number (586). See workhead assembly drawing. To remedy this condition, first remove the reservoir drain plug and drain off all the oil in the reservoir. Next, remove parts, 3/8” pipe plug (588), check valve spring (579) and valve ball (586) then clean out port hole and valve seat thoroughly. Replace and using a small piece of brass rod as a drift, tap the brass rod lightly to seat the ball properly. Replace spring and plug using extreme care to prevent dirt from entering. Replace the drain plug and refill the reservoir with clean filtered oil.

If above procedure does not correct the condition, air may be present in the chamber above the piston and should be removed as directed in **Filling Press with Oil** paragraph III.

SYMPTOM	CAUSE	SOLUTION
Oil leaking from piston oil seal.	1) Reservoir is over filled. * 2) Piston Packing is worn or damaged.	1) Drain excess oil. 2) Replace Piston Packing.
Press will not hold pressure.	1) Check Ball is contaminated. 2) Ball and Seat have poor contact. 3) Piston Packing is worn or damaged.	1) Remove and clean Check Balls and Seats. 2) Reseat Ball on Seat. 3) Replace Piston Packing.
Press will not build rated tonnage.	1) Pump Plunger Leather is worn or damaged. 2) See 1,2,3 Above. 3) Gauge is defective.	1) Replace Pump Plunger leather. 2) See 1,2,3 Above. 3) Replace Gauge.
Oil leaking from pump plunger	1) Packing Nut Loose. 2) Worn Packings.	1) Tighten Packing Nut. 2) Replace packings.
Oil leaking from release valve rod	1) Valve Rod Packing Nut is Loose 2) Packings are worn.	1) Tighten Packing Nut. 2) Replace Packings.
Pump handle drifts up.	Defective Check Ball or Check Ball Spring.	Clean Check Ball, Reseat. Replace Spring.
Ram will not return.	Return Spring damaged. Piston is bent or damaged. Piston Packing is defective.	Replace Spring. Replace Piston. Replace Piston Packing.
* Note: If press leaks around the ram but holds pressure the reservoir has been overfilled.		



724 Robbins Road
 Grand Haven, MI 49417
 Phone: 616-842-7110 800-937-3253
 Fax: 616-842-0859 800-846-3253
 Web: www.dakecorp.com
 E-mail: customerservice@dakecorp.com
technicalservice@dakecorp.com

HANDPUMP ASSEMBLY

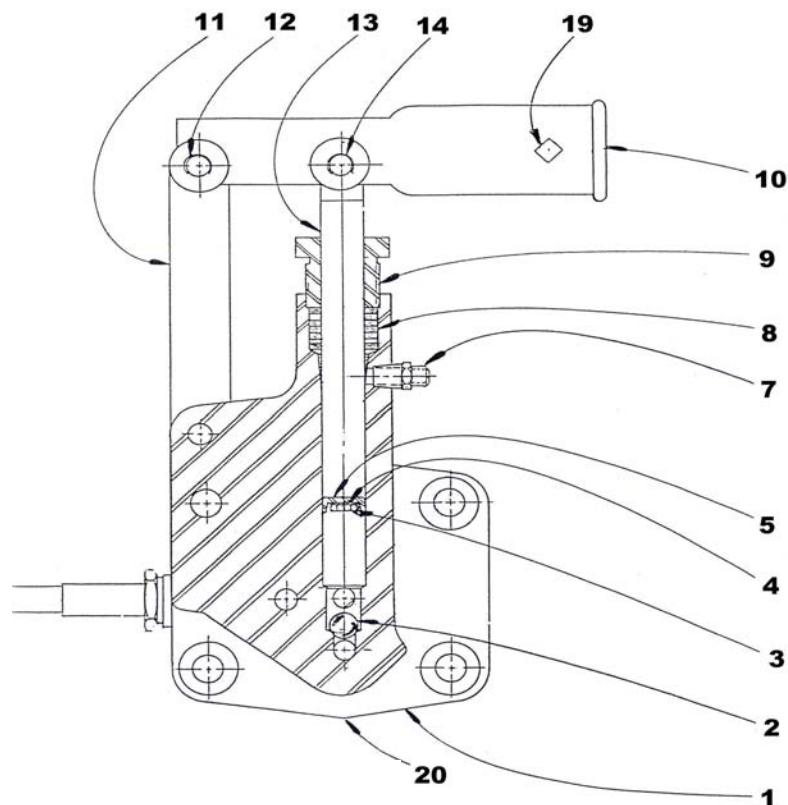
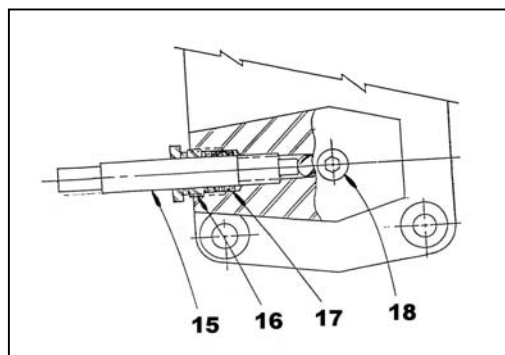
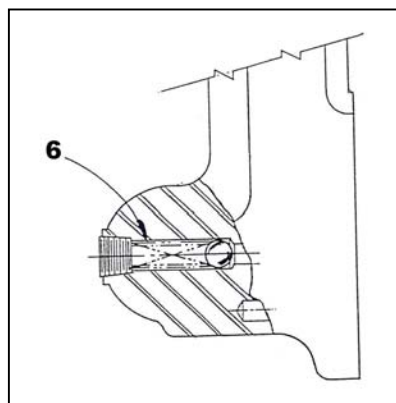

Item	Qty	Description	Part No.
1	1	Pump Body	546
2	3	Ball valve 1/2" Dia.	586
3	1	1/4"-20 x 1/2" Nylock Hex Cap Screw	28297
4	1	Washer #12 Flat	43629
5	1	Pump Plunger Leather	599
6	1	Check Valve Spring	579
7	1	Fitting, Tube, Poly-Tite	71413
8	7	Pump Packing	573
9	1	Pump Packing Nut	551
10	1	Handle Socket	550
11	1	Handle Socket Link	555
12	6	3/8" Retaining Rings	43972
13	1	Pump Plunger	554
14	3	Handle Socket Pin	594
15	1	Valve Rod	1129
16	1	Valve Rod Packing Nut	576
17	8	Valve Rod Packing	987
18	1	3/8" Pipe Plug	588
19	1	3/8"-16 x 5/8" Set Screw	43589
20	1	Pump Gasket	591
Hand Pump Assembly Complete			700887
Repair Kit – Cylinder & Hand Pump Assembly (Includes – Items 5,8,17,20,26B,27,34,38)			701292

WORKHEAD ASSEMBLY

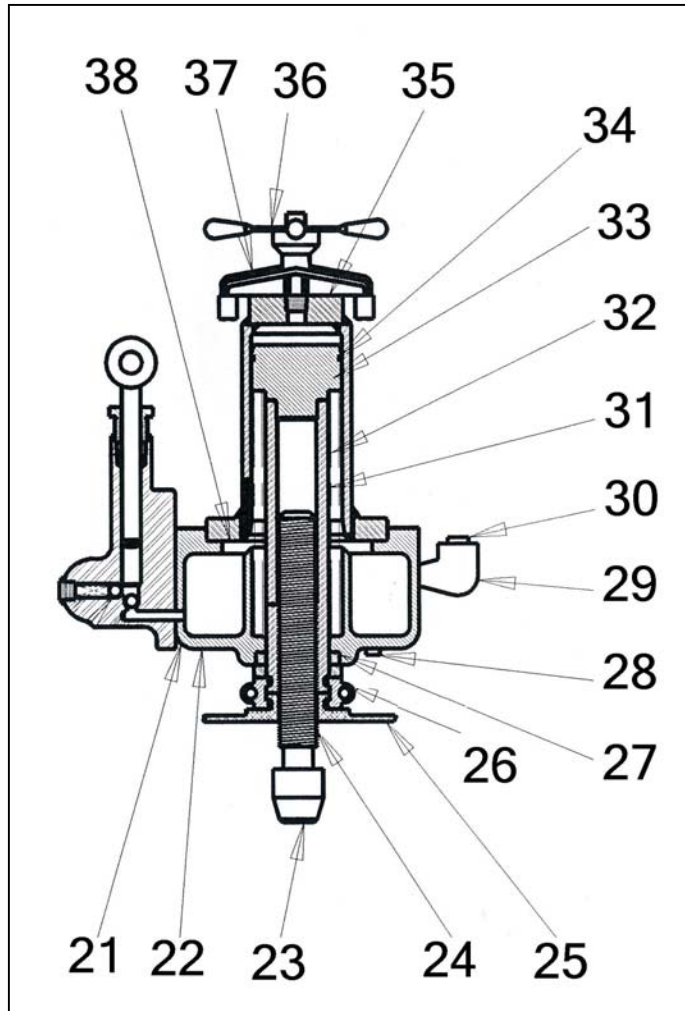

Item	Qty	Description	Part No.
21	1	Pump Gasket	591
22	1	Reservoir	695
23	1	Screw Nose – Flat	572
	1	Screw Nose – V-ram nose	344
24	1	Screw	559
25	1	Handwheel	716520
26A	1	Clamp Ring Assembly	718
26B	1	Piston Bumper	738
27	1	Oil Seal	1477
28	1	Pipe Plug, 1/8" NPTF	589
29	1	Elbow, Pipe Street 1/2"	590
30	1	Pipe Plug, 1/2" NPTF	596
31	1	Spring, Ram	705
32 & 33	1	Piston Assembly (Serial No. < 192522)	701802
		Piston Assembly (Serial No. > 192523)	716223
34	1	Piston Leather (Serial No. < 192522)	706
		Packing Ring (Serial No. > 192523)	17942
35	1	Cylinder – 75 Ton	693
36	1	Handwheel	716521
37	1	Yoke	732
38	1	Gasket, Cylinder	1478
Repair Kit – Cylinder & Hand Pump Assembly (Includes – Items 5,8,17,20,26B,27,34,38)			701292

FRAME ASSEMBLY

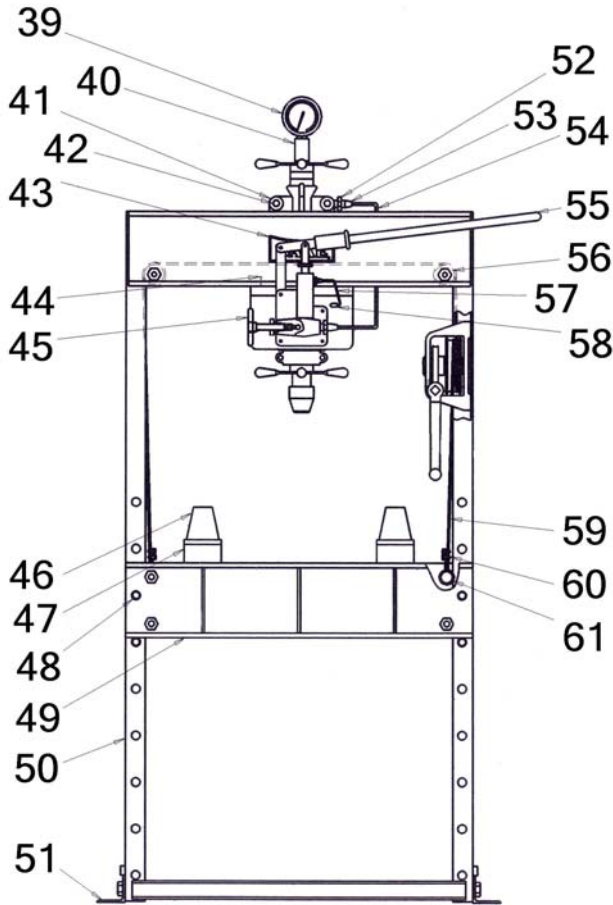

Item	Qty	Description	Part No.
39	1	Gauge	71267
40	1	Bushing	81384
40	1	Gauge Extension	731
41	4	Roller	592
42	2	Roller Shaft	733
	4	Retaining Ring	43975
43	1	Dake Name Plate	81002
44	1	Air Vent Tube	632
45	1	Handwheel	10631
46	2	V-Block	336
47	2	Table Plate	702
48	6	Table Pins	569
49	2	Table Channel	706945
50	1	Frame only	706943
51	2	Base Angle	566
52	2	Fitting, 3/8 NPT, 37°	1251
53	2	Fitting Nut	46614
	2	Fitting Sleeve	51454
54	1	Tube Assembly (53 & 54)	700121
55	1	Handle	218
56	2	Pulley	727
	2	Pulley Bolt	43361
	2	Pulley Nut	43916
	2	Pulley Lockwasher	43647
57	1	Vent Tube	67761
58	2	Fitting, Tube, Poly-Tite	71413
59	17'	Cable (sold in feet)	45953
60	4	Cable Clamps	991
61	4	Table Spacer	86488
	4	Bolt, Hex Head 5/8"	79983
	4	Hex Nut 5/8"	43917
	4	Lock Washer 5/8"	43648

TABLE HOIST

Item	Qty	Description	Part No.
62	1	Hand Crank Assembly	701653
63	1	Worm Shaft	384
64	1	Retaining Ring	27437
65	2	Worm Key	47364
66	1	Worm	385
67	1	Hoist Frame	725
68	1	Hex Cap Screw	43335
69	1	Hex Nut	43912
70	1	Drum Shaft	724
71	1	Drum Key	737
72	1	Worm Gear	736
73	1	Cable Drum	723
74	1	Retaining Ring	43992
75	1	Complete Table Hoist Assembly	700112

